

PRODUCT SPECIFICATION

ITEM CODE: AQF-BB-TWIN-2

**2 STAGE AQF BIG BLUE 10" / 20"
FILTRATION SYSTEM WITH STAND**

**1st/2nd STAGE:
AQF-BB 10" / 20" OPAQUE HOUSING**

2STAGE FOOT BRACKET

IN/OUTLET: 1" NPT

FLOW RATE: 10": 60GPM / 20": 80GPM

MAX. PRESSURE: 100PSI

MAX. TEMPERATURE: 120°F (50°C)

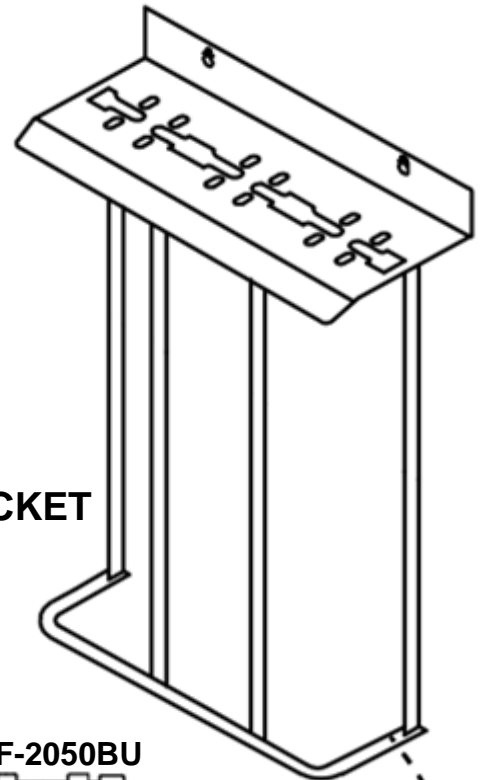

2 STAGE STAND BRACKET

AQF-2050BU



**APC-2045 APC-1045
CARBON BLOCK CARTRIDGE**

AQF-1050BU

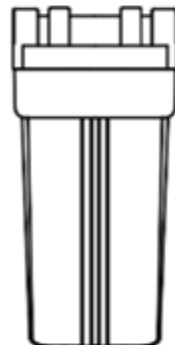

or

AQF-2050BU



**PPS-2045 PPS-1045
NSF SEDIMENT CARTRIDGE**

AQF-1050BU



or

**SOURCE
WATER**

MAIN PARTS:

1. **AQF-1050 NSF BIG BLUE FILTER HOUSING, OPAQUE, 1" NPT IN/OUTLET**
AQF-2050 NSF BIG BLUE FILTER HOUSING, OPAQUE, 1" NPT IN/OUTLET

2. **FL-PPS-1045 NSF Sediment Filter**
FL-PPS-2045 NSF Sediment Filter

3. **APC-1045 Carbon Block Filter**
APC-2045 Carbon Block Filter

4. **BK-2BB-STAND-10 / 20 Coated Metal Bracket**

5. **WRS-BB Wrench for AQF big blue housing**

NSF International

RECOGNIZES

Aquapro Industrial Co., Ltd.

Facility: Nantou County, Taiwan

AS COMPLYING WITH NSF/ANSI 42 AND ALL APPLICABLE REQUIREMENTS.

PRODUCTS APPEARING IN THE NSF OFFICIAL LISTING ARE
AUTHORIZED TO BEAR THE NSF MARK.

This certificate is the property of NSF International and must be returned upon request. For the most current and complete information, please access NSF's website (www.nsf.org).

A handwritten signature in black ink that reads "Richard Andrew".

August 10, 2012
Certificate# C0091259 - 02

Richard Andrew, General Manager
Drinking Water Treatment Units